



Driver LC 100W 24V Ip SNC
essence series

Product description

- Constant voltage LED Driver
- Output voltage 24 V
- Max. output power 100 W
- Dimmable via PWM LED dimmers
- Nominal life-time up to 50,000 h
- 5-year guarantee

Typical application

- Cove lighting, facade accent lighting, ceiling integration

Technical details

- 24 V, 100 W
- Very good THD performance in wide load range < 5 %
- Output LF voltage ripple (< 120 Hz) \pm 1.5 %
- Small cross section
- Push terminal for simple wiring

System solution

- Tridonic LLE-FLEX ADV G2 600, 1,200, 1,800 lm/m
- Tridonic LLE-FLEX EXC 600, 1,200, 1,800, 2,500 lm/m
- In connection with Flex accessories wire to PCB plug



Standards, page 3



IP20 SELV 

Driver LC 100W 24V Ip SNC

essence series

Technical data

Rated supply voltage	220 – 240 V
AC voltage range	198 – 264 V
Mains frequency	50 / 60 Hz
Oversvoltage protection	320 V, 48 h
Typ. current (at 230 V, 50 Hz, full load) [®]	486 mA
Leakage current (at 230 V, 50 Hz, full load) [®]	< 219 µA
Max. input power	113 W
Typ. efficiency (at 230 V / 50 Hz / full load)	90.8 %
λ (at 230 V, 50 Hz, full load) [®]	0.98
Typ. input current in no-load operation	63 mA
Typ. input power in no-load operation	1.8 W
In-rush current (peak / duration)	40 A / 186 µs
THD (at 230 V, 50 Hz, full load) [®]	< 4 %
Starting time (at 230 V, 50 Hz, full load) [®]	< 0.5 s
Turn off time (at 230 V, 50 Hz, full load)	< 0.5 s
Hold on time at power failure (output)	0 s
Output voltage tolerance	± 1 V
Output LF voltage ripple (< 120 Hz)	± 1.5 %
Max. output voltage (no-load voltage)	25 V
Burst capability	1 kV
Mains surge capability (between L – N)	1 kV
Mains surge capability (between L/N – PE)	2 kV
Dimensions L x W x H	360 x 30 x 21 mm

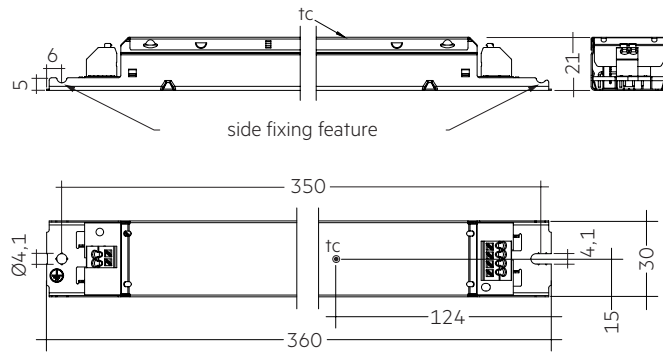

Ordering data

Type	Article number	Packaging carton	Packaging, low volume	Packaging, high volume	Weight per pc.
LC 100W 24V Ip SNC	87500670	50 pc(s).	650 pc(s).	1,950 pc(s).	0.246 kg

Specific technical data

Type	Load	Forward voltage	Output current	Max. output power (at 24 V, full load)	Typ. power consumption (at 24 V, full load)	Typ. current consumption (at 24 V, full load)	Max. casing temperature tc	Ambient temperature ta max.
LC 100W 24V Ip SNC	30 %	24 V	1,250 mA	30 W	34.5 W	169 mA	75 °C	-20 ... +50 °C
	40 %	24 V	1,667 mA	40 W	45.1 W	211 mA	75 °C	-20 ... +50 °C
	50 %	24 V	2,083 mA	50 W	55.7 W	255 mA	80 °C	-20 ... +50 °C
	60 %	24 V	2,500 mA	60 W	66.4 W	300 mA	80 °C	-20 ... +50 °C
	70 %	24 V	2,917 mA	70 W	77.3 W	345 mA	80 °C	-20 ... +50 °C
	80 %	24 V	3,333 mA	80 W	88.2 W	392 mA	90 °C	-20 ... +50 °C
	90 %	24 V	3,750 mA	90 W	99.1 W	439 mA	90 °C	-20 ... +50 °C
	100 %	24 V	4,167 mA	100 W	110.2 W	486 mA	90 °C	-20 ... +50 °C

[®] Valid at 100 % dimming level.

1. Standards

EN 55015
EN 61000-3-2
EN 61000-3-3
EN 61347-1
EN 61347-2-13
EN 62384
EN 61547

2. Thermal details and life-time

2.1 Expected life-time

Expected lifetime					
Type	Output load	ta	40 °C	45 °C	50 °C
	≥ 80 ... ≤ 100 W	tc	80 °C	85 °C	90 °C
		Life-time	70,000 h	>50,000 h	35,000 h
LC 100W 24V Ip SNC	≥ 50 ... < 80 W	tc	70 °C	75 °C	80 °C
		Life-time	> 100,000 h	> 100,000 h	100,000 h
	< 50 W	tc	65 °C	70 °C	75 °C
		Life-time	> 100,000 h	> 100,000 h	> 100,000 h

The LED control gear is designed for a life-time stated above under reference conditions and with a failure probability of less than 10 %.

The relation of tc to ta temperature depends also on the luminaire design.

If the measured tc temperature is approx. 5 K below tc max., ta temperature should be checked and eventually critical components (e.g. ELCAP) measured. Detailed information on request.

3. Installation / wiring

3.1 Circuit diagram

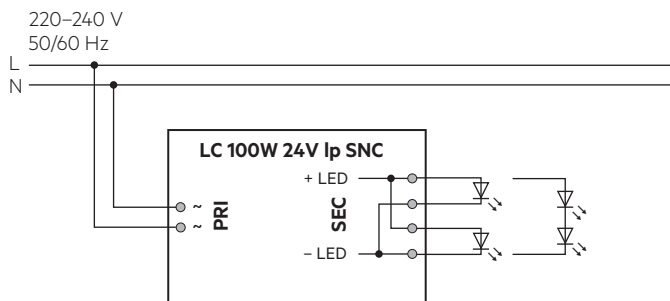

3.2 Wiring type and cross section

The wiring can be stranded wires with ferrules or rigid wires with a cross section of 0.5 – 1.5 mm². Strip 7.2 – 8.8 mm of insulation from the cables to ensure perfect operation of the push-wire terminals.

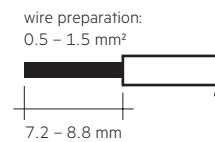

3.3 Release of the wiring

Press down the “push button” and remove the cable from front.

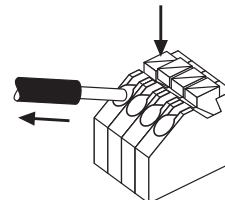

3.4 Wiring guidelines

- The cables should be run separately from the mains connections and mains cables to ensure good EMC conditions.
- The LED wiring should be kept as short as possible to ensure good EMC. The max. secondary cable length is 2 m (4 m circuit).
- The LED Driver has no inverse-polarity protection on the secondary side. Wrong polarity can damage LED modules with no inverse-polarity protection.
- Wrong wiring of the LED Driver can lead to malfunction or irreparable damage.
- To avoid the damage of the Driver, the wiring must be protected against short circuits to earth (Sharp edged metal parts, metal cable clips, louver, etc.).

3.5 Earth connection

The earth connection is conducted as protection earth (PE). The LED Driver can be earthed via metal housing. If the LED Driver will be earthed, protection earth (PE) has to be used. There is no earth connection required for the functionality of the LED Driver. Earth connection is recommended to improve following behaviour:

- Electromagnetic interferences (EMI)
- LED glowing at standby
- Transmission of mains transients to the LED output

In general it is recommended to earth the LED Driver if the LED module is mounted on earthed luminaire parts respectively heat sinks and thereby representing a high capacity against earth.

3.6 Installation instructions

The LED module and all contact points within the wiring must be sufficiently insulated against 500 V surge voltage. Air and creepage distance must be maintained.

4. Electrical values

4.1 Efficiency vs. load

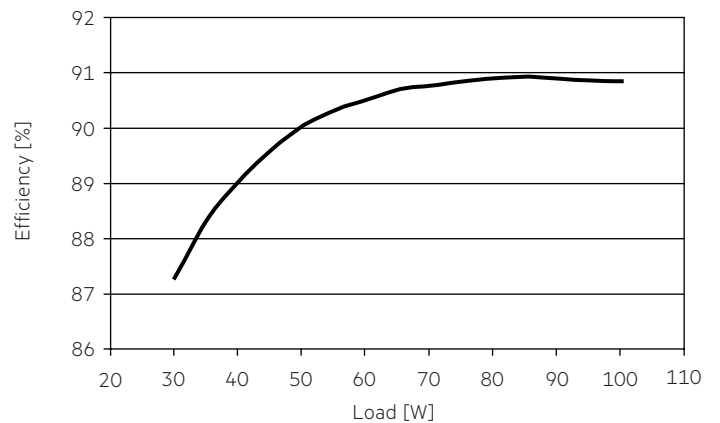

4.2 Power factor vs. Load

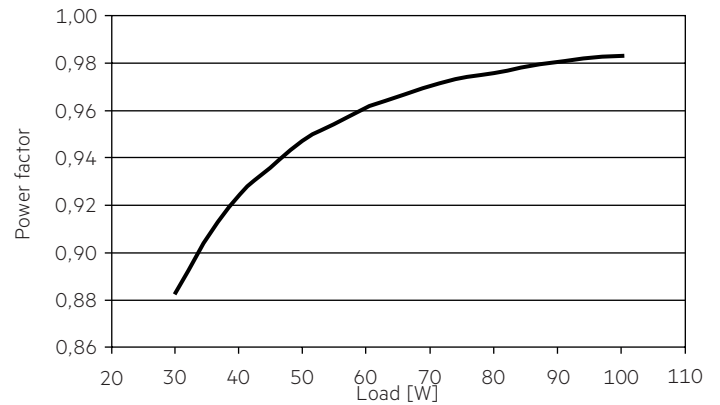

4.3 Input power vs. Load

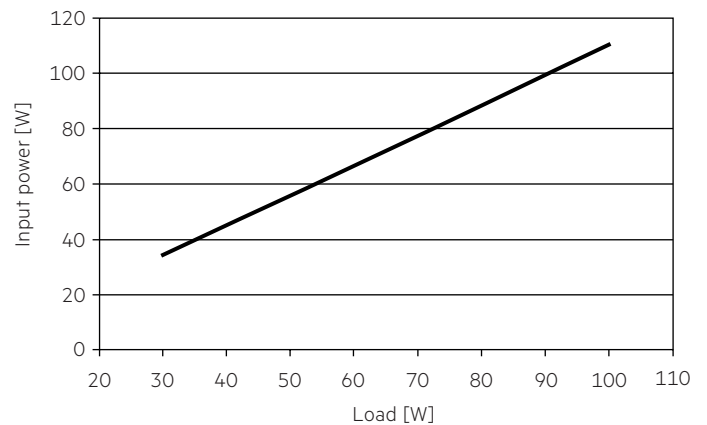

4.4 Input current vs. Load

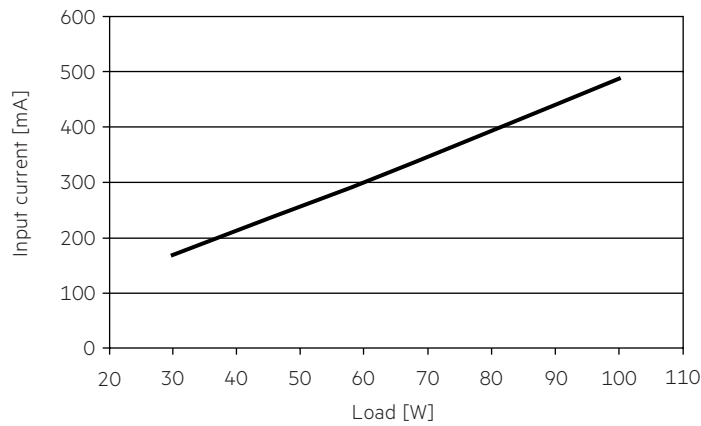

4.5 THD vs. Load

THD without harmonic < 5 mA (0.6 %) of the input current:

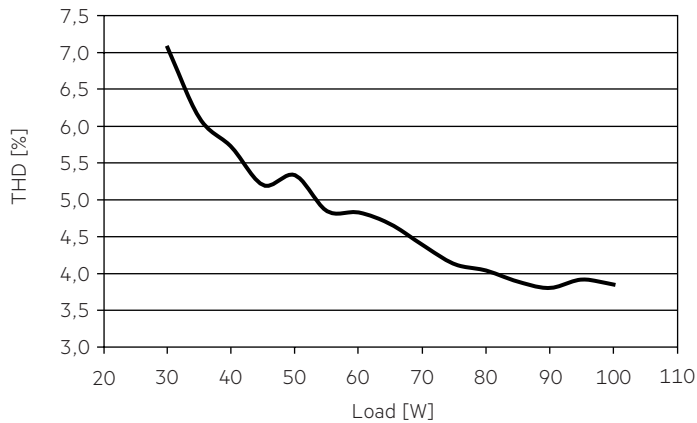

4.6 Maximum loading of automatic circuit breakers

Automatic circuit breaker type	C10	C13	C16	C20	B10	B13	B16	B20	Inrush current	
Installation Ø	1.5 mm ²	1.5 mm ²	1.5 mm ²	2.5 mm ²	1.5 mm ²	1.5 mm ²	1.5 mm ²	2.5 mm ²	I_{max}	time
LC 100W 24V Ip SNC	22	30	38	48	13	18	23	29	40 A	186 µs

Typical values for MCB from ABB series S200 as reference.
Actual values can differ due to used MCB types and installation environment.

4.7 Harmonic distortion in the mains supply (at 230 V / 50 Hz and full load) in %

	THD	3.	5.	7.	9.	11.
LC 100W 24V Ip SNC	< 4	< 2	< 3	< 2	< 2	< 2

Acc. to 6100-3-2. Harmonics < 5 mA or < 0.6 % (whatever is greater) of the input current are not considered for calculation of THD.

5. Functions

5.1 Overload protection

If the output current range is exceeded, the LED will flicker, and output voltage will be reduced.
When fault is removed, the driver can go back to work automatically without resetting input main power.

5.2 Overtemperature protection

The LED Driver is protected against temporary thermal overheating. If the temperature limit is exceeded the LED will flicker, and restart automatically after the driver cold down. The temperature protection is activated approx. + 15 °C above T_c max.

5.3 Short-circuit behaviour

In case of a short circuit at the LED output the LED output is switched off. When fault is removed, the driver can go back to work automatically without resetting input main power.

5.4 No-load operation

The LED Driver will not be damaged in the no-load operation. When the output is floating and doesn't connect the LED modules, the output voltage will keep the max. voltage (< 25 V). After connecting the LED load, the driver works normally without resetting the main power.

5.5 Hot plug-in

Hot plug-in is supported.
If a LED load is connected, the device does not need to be restarted before the output will be activated again.

7. Miscellaneous

7.1 Isolation and electric strength testing of luminaires

Electronic devices can be damaged by high voltage. This has to be considered during the routine testing of the luminaires in production.

According to IEC 60598-1 Annex Q (informative only!) or ENEC 303-Annex A, each luminaire should be submitted to an isolation test with 500 V_{DC} for 1 second. This test voltage should be connected between the interconnected phase and neutral terminals and the earth terminal.
The isolation resistance must be at least 2 MΩ.

As an alternative, IEC 60598-1 Annex Q describes a test of the electrical strength with 1500 V_{AC} (or 1.414 x 1500 V_{DC}). To avoid damage to the electronic devices this test must not be conducted.

7.2 Conditions of use and storage

Humidity: 5 % up to max. 85 %,
not condensed
(max. 56 days/year at 85 %)

Storage temperature: -40 °C up to max. +80 °C

The devices have to be acclimatised to the specified temperature range (ta) before they can be operated.

7.3 Additional information

Additional technical information at www.tridonic.com → Technical Data

Guarantee conditions at www.tridonic.com → Services

Life-time declarations are informative and represent no warranty claim.
No warranty if device was opened.