



Driver LCI 75W 250-500mA flexC NF h21 EXC3 (INDUSTRY)

excite series non-SELV

Product description

- Constant current built-in Driver for LED, particularly suitable for industrial applications in tough environments with elevated ambient temperatures such as cold warehouses or factories
- For class I luminaires
- Adjustable output current between 250 and 500 mA
- Max. output power 75 W
- Suitable for mains voltage peaks (burst/surge) up to 4 kV
- Expanded temperature range of -40 ... +80 °C
- Nominal lifetime up to 90,000 h (at ta 70 °C)
- 5 years guarantee (conditions at www.tridonic.com)



Housing properties

- Low profile metal casing with white cover
- Type of protection IP20

Interfaces

- Near field communication (NFC)
- Terminal blocks: 0° push terminals

Functions

- Adjustable output current in 1-mA-steps (NFC)
- Intelligent Temperature Guard (overtemperature protection)
- Intelligent Voltage Guard (overvoltage and undervoltage monitoring)
- Protective features (overtemperature, short-circuit, overload, no-load, input voltage range)
- Suitable for emergency lighting acc. to EN 50172

Benefits

- Flexible configuration via companionSUITE (NFC)
- Application-oriented operating window for maximum compatibility
- Extended vibration damping
- Increased safety through robust design and advanced testing under extreme test conditions
- High reliability through the selection of exclusive components

Typical applications

- For linear/area lighting in industry applications



Standards, page 3



IP20

Driver LCI 75W 250-500mA flexC NF h21 EXC3 (INDUSTRY)

excite series non-SELV

Technical data

Rated supply voltage	220 – 240 V
AC voltage range	198 – 264 V
DC voltage range	176 – 280 V
Mains frequency	0 / 50 / 60 Hz
Overvoltage protection	320 V AC, 48 h
Typ. current (at 230 V, 50 Hz, full load) ^{① ②}	360 mA
Typ. current (220 V, 0 Hz, full load, EOFx dimlevel) ^{① ②}	60 mA
Leakage current (at 230 V, 50 Hz, full load) ^{① ②}	< 350 µA
Max. input power	81 W
Typ. efficiency (at 230 V / 50 Hz / full load) ^②	94 %
λ (at 230 V, 50 Hz, full load) ^①	0.97
Typ. input current in no-load operation	38 mA
Typ. input power in no-load operation	0.5 W
In-rush current (peak / duration)	4 A / 2,000 µs
THD (at 230 V, 50 Hz, full load) ^①	< 10 %
Starting time (at 230 V, 50 Hz, full load) ^①	< 0.5 s
Starting time (DC mode)	< 0.5 s
Switchover time (AC/DC) ^②	< 0.5 s
Turn off time (at 230 V, 50 Hz, full load)	< 30 ms
Output current tolerance ^{① ②}	± 5 %
Max. output current peak (non-repetitive)	≤ Output current + 35 %
Output LF current ripple (< 120 Hz) ^①	± 3 %
Output P_{ST}^{LM} (at full load)	≤ 1
Output SVM (at full load)	≤ 0.4
Max. output voltage (no-load voltage)	300 V
Mains surge capability (between L – N)	4 kV
Mains surge capability (between L/N – PE)	4 kV
Surge voltage at output side (against PE)	4.5 kV
Type of protection	IP20
Lifetime	up to 90,000 h
Guarantee (conditions at www.tridonic.com)	5 years
Dimensions L x W x H	360 x 30 x 21 mm

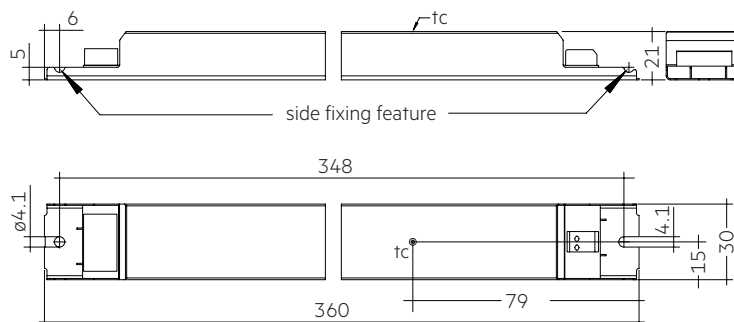

Ordering data

Type	Article number	Packaging carton	Packaging pallet	Weight per pc.
LCI 75/250-500/230 flexC NF h21 EXC3	28003510	10 pc(s).	520 pc(s).	0.251 kg

Specific technical data

Type	Output current ^{① ②}	Min. forward voltage	Max. forward voltage	Max. output power	Typ. power consumption (at 230 V, 50 Hz, full load)	Typ. current consumption (at 230 V, 50 Hz, full load)	Max. casing temperature tc	Ambient temperature ta max.
LCI 75/250-500/230 flexC NF h21 EXC3	250 mA	140 V	230.0 V	57.5 W	61.0 W	275 mA	85 °C	-40 ... +80 °C
	300 mA	140 V	230.0 V	69.0 W	73.0 W	325 mA	85 °C	-40 ... +80 °C
	350 mA	140 V	214.3 V	75.0 W	79.2 W	350 mA	85 °C	-40 ... +80 °C
	400 mA	140 V	187.5 V	75.0 W	79.4 W	350 mA	90 °C	-40 ... +80 °C
	450 mA	140 V	166.6 V	75.0 W	80.0 W	355 mA	90 °C	-40 ... +80 °C
	500 mA	140 V	150.0 V	75.0 W	80.5 W	360 mA	90 °C	-40 ... +80 °C

^① Valid at max. output current setting at ta = 25 °C.

^② Depending on the selected output current.

^③ The table only lists a number of possible operating points but does not cover each single point. The output current can be set within the total value range in 1-mA-steps.

^④ Output current is mean value.

^⑤ Valid for immediate change of power supply type otherwise the starting time is valid.

1. Standards

EN 55015
EN 61000-3-2
EN 61000-3-3
EN 61000-4-4
EN 61000-4-5
EN 61347-1
EN 61347-2-13
EN 61547
EN 62384

According to EN 50172 for use in central battery systems

According to EN 60598-2-22 suitable for emergency lighting installations

2. Thermal details and lifetime

2.1 Expected lifetime

Type	Output current	ta	50 °C	55 °C	60 °C	65 °C	70 °C	75 °C	80 °C
LCI 75/250-500/230 flexC NF h21 EXC3	< 400 mA	tc	55 °C	60 °C	65 °C	70 °C	75 °C	80 °C	85 °C
		Lifetime	> 120,000 h	> 120,000 h	> 120,000 h	> 120,000 h	> 90,000 h	> 60,000 h	> 45,000 h
	≥ 400 mA	tc	60 °C	65 °C	70 °C	75 °C	80 °C	85 °C	90 °C
		Lifetime	> 120,000 h	> 120,000 h	> 120,000 h	> 120,000 h	> 90,000 h	> 60,000 h	> 45,000 h

The LED Driver is designed for a lifetime stated above under reference conditions and with a failure probability of less than 10 %.

The relation of tc to ta temperature depends also on the luminaire design.

If the measured tc temperature is approx. 5 K below tc max., ta temperature should be checked and eventually critical components (e.g. ELCAP) measured. Detailed information on request.

3. Installation / wiring

3.1 Circuit diagram

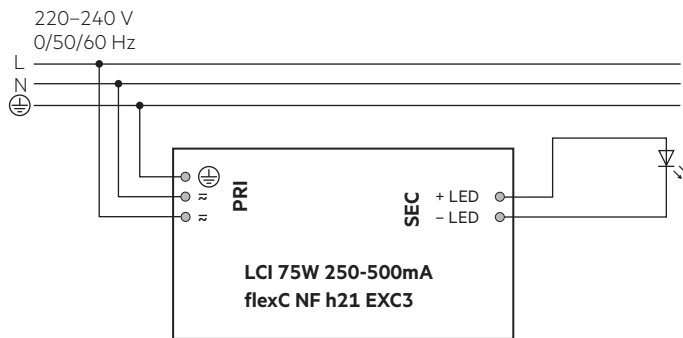

3.2 Wiring type and cross section

Solid wire with a cross section of 0.5 – 1.5 mm². Strip 8 – 9 mm of insulation from the cables to ensure perfect operation of terminals.

LED module/LED Driver/supply

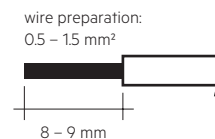

3.3 Loose wiring

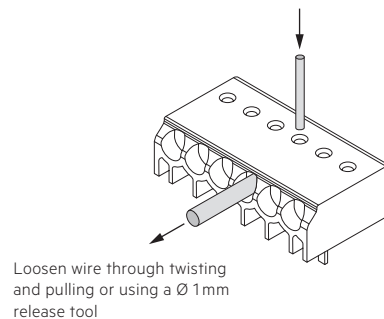

3.4 Wiring guidelines

- The cables should be run separately from the mains connections and mains cables to ensure good EMC conditions.
- The LED wiring should be kept as short as possible to ensure good EMC. The max. secondary cable length is 2 m (4 m circuit).
- Secondary switching is not permitted.
- The LED Driver has no inverse-polarity protection on the secondary side. Wrong polarity can damage LED modules with no inverse-polarity protection.
- Wrong wiring of the LED Driver can lead to malfunction or irreparable damage.
- With mains transients of 4 kV can voltage peaks up to 4 kV occur against PE at the output of the LED Driver. This has to be considered concerning the dielectric strength of the LED module (insulation against PE).
- To avoid the damage of the Driver, the wiring must be protected against short circuits to earth (sharp edged metal parts, metal cable clips, louver, etc.).

3.5 Hot plug-in

Hot plug-in is not supported due to residual output voltage of > 0 V. If a LED load is connected the device has to be restarted before the output will be activated again. This can be done via mains reset.

3.6 Earth connection

Suitable for luminaires of protection class I only. The earth connection is conducted as protection earth (PE). The LED Driver can be earthed via earth terminal or metal housing.

3.7 Replace LED module

1. Mains off
2. Remove LED module
3. Wait for 30 seconds
4. Connect LED module again

Hot plug-in or secondary switching of LEDs is not permitted and may cause a very high current to the LEDs.

4. Electrical values

4.1 Operating window

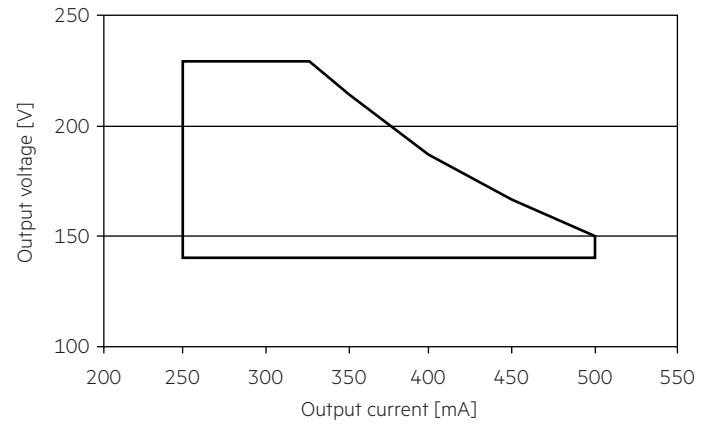

Make sure that the LED Driver is operated within the given window under all operating conditions.

4.2 Efficiency vs load

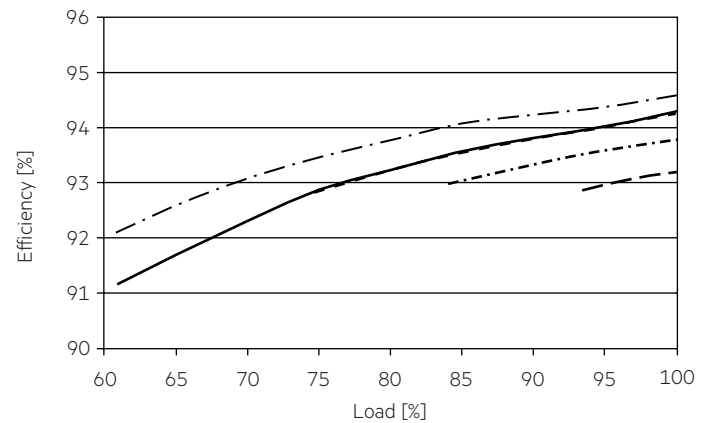

4.3 Power factor vs load

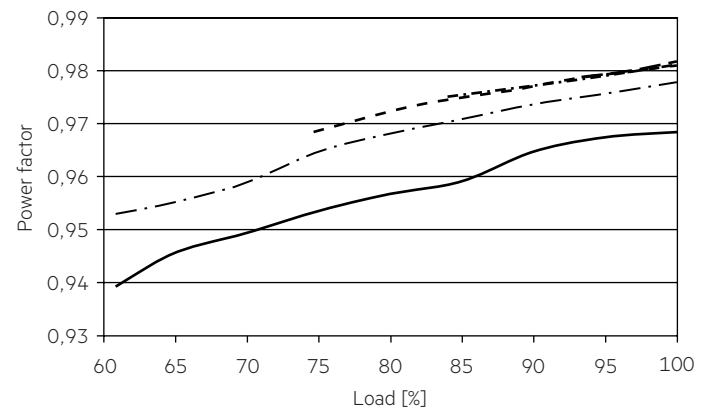

- 500 mA
- · - · - 450 mA
- - - - 400 mA
- · - · - 300 mA
- 250 mA

4.4 THD vs load

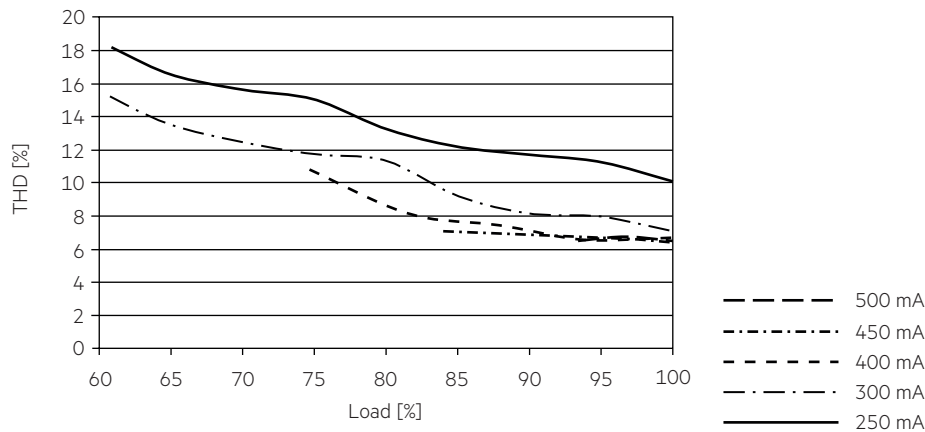

100 % load corresponds to the max. output power (full load) according to the table on page 2.

4.5 Maximum loading of automatic circuit breakers

Automatic circuit breaker type	C10	C13	C16	C20	B10	B13	B16	B20	Inrush current	
Installation Ø	1.5 mm ²	1.5 mm ²	2.5 mm ²	4 mm ²	1.5 mm ²	1.5 mm ²	2.5 mm ²	4 mm ²	I_{max}	time
LCI 75/250-500/230 flexC NF h21 EXC3	34	44	56	68	20	26	33	41	4 A	2,000 µs

This are max. values! Please consider not to exceed the maximum current of the circuit breaker. Calculation uses typical values from ABB series S200 as a reference. Actual values may differ due to used circuit breaker types and installation environment.

4.6 Harmonic distortion in the mains supply (at 230 V / 50 Hz and full load) in %

	THD	3.	5.	7.	9.	11.
LCI 75/250-500/230 flexC NF h21 EXC3	<10	<10	<5	<5	<3	<3

4.7 Insulation matrix

	Mains	LED	Functional earth
Mains	-	-	•
LED	-	-	•
Functional earth	•	•	-

- Represents basic insulation
- Represents double or reinforced insulation

5. Software / Programming / Interfaces

5.1 Software / programming

With appropriate software and interface different functions can be activated and various parameters can be configured in the LED Driver. The Driver supports the following software and interfaces:

Software / hardware for configuration:

- companionSUITE (deviceGENERATOR, deviceCONFIGURATOR, deviceANALYSER)

Interfaces for data transfer:

- NFC

5.2 Nearfield communication (NFC)



The NFC Interface allows wireless communication with the LED Driver. This interface offers the option to write configuration and to read configuration, errors and events with the companionSUITE. A correct communication between the LED Driver and the NFC antenna can only be guaranteed if the antenna is placed directly on the Driver. Any material placed between the LED Driver and the NFC antenna can cause a deterioration of the communication quality. After programming the device via NFC power up the device one time for one second till the deviceANALYSER can read out the parameters. We recommend the use of following NFC antenna: www.tridonic.com/nfc-readers

NFC is complied with ISO/IEC 15963 standard.

6. Functions

 companionSUITE:
NFC

The companionSUITE with deviceGENERATOR, deviceCONFIGURATOR and deviceANALYSER is available via our WEB page:
<https://www.tridonic.com/com/en/products/companionsuite.asp>

Icon	Function	NFC
	LED current	

6.1 LED current



The LED output current must be adapted to the connected LED module.
The value is limited by the current range of the respective device.

6.2 DC operation



In emergency light systems with a central battery supply the DC recognition function uses the input voltage to detect if emergency mode is present. The LED Driver then automatically switches to DC mode. Without DC recognition different and more complex solutions would have to be applied in order to detect emergency mode. DC recognition is integrated in the device as standard. No additional commissioning is necessary for activation.

The LED Driver is designed to operate on DC voltage and pulsed DC voltage.

Light output level in DC operation: 15 %, $EOF_i = 0.13$

The voltage-dependent input current of Driver incl. LED module is depending on the used load.
The voltage-dependent no-load current of Driver (without or defect LED module) is for:
AC: < 38 mA
DC: < 8 mA

6.3 Intelligent Temperature Guard (ITG)



The intelligent temperature guard protects the LED Driver from thermal overheating by reducing the output power or switching off in case of operation above the thermal limits of the luminaire or ballast. Depending on the luminaire design, the ITG operates at about 5 to 10 °C above t_c max.

If temperature threshold values are exceeded, the LED output current is limited.

7. Protective features

7.1 Overtemperature protection

The LED Driver is protected against temporary thermal overheating. If the temperature limit is exceeded the output current of the LED module(s) is reduced. The temperature protection is activated above $t_{c\ max}$. The activation temperature differs depending on the LED load. On DC operation this function is deactivated to fulfill emergency requirements.

7.2 Short-circuit behaviour

In case of a short-circuit at the LED output the LED output is switched off. After restart of the LED Driver the output will be activated again. The restart can be done via mains reset. The device will recover automatically.

7.3 No-load operation

The LED Driver will not be damaged in no-load operation. The output will be deactivated and is therefore free of voltage. If a LED load is connected, the device has to be restarted before the output will be activated again.

7.4 Overload protection

If the maximum load is exceeded by a defined internal limit, the LED Driver turns off the LED output. After restart of the LED Driver the output will be activated again. The restart can be done via mains reset. The device will recover automatically.

8. Miscellaneous

8.1 Insulation and electric strength testing of luminaires

Electronic devices can be damaged by high voltage. This has to be considered during the routine testing of the luminaires in production.

According to IEC 60598-1 Annex Q (informative only!) or ENEC 303-Annex A, each luminaire should be submitted to an insulation test with 500 V_{DC} for 1 second. This test voltage should be connected between the interconnected phase and neutral terminals and the earth terminal. The insulation resistance must be at least 2 MΩ.

As an alternative, IEC 60598-1 Annex Q describes a test of the electrical strength with 1500 V_{AC} (or 1.414 x 1500 V_{DC}). To avoid damage to the electronic devices this test must not be conducted.

8.2 Conditions of use and storage

Humidity: 5 % up to max. 85 %,
not condensed
(max. 56 days/year at 85 %)

Storage temperature: -40 °C up to max. +80 °C

The devices have to be acclimatised to the specified temperature range (ta) before they can be operated.

8.3 Maximum number of switching cycles

All LED Driver are tested with 50,000 switching cycles. The actually achieved number of switching cycles is significantly higher.

8.4 Additional information

Additional technical information at www.tridonic.com → Technical Data

Lifetime declarations are informative and represent no warranty claim. No warranty if device was opened.