

EM converterLED BASIC 50 V

BASIC series

Product description

- Emergency lighting LED Driver for manual testing
- For self-contained emergency lighting
- For LED modules with a forward voltage of 10 – 52 V
- SELV for output voltage < 60 V DC
- Low profile casing (21 x 30 mm cross-section)
- For luminaire installation
- 5-year guarantee

Properties

- Non maintained operation
- 1 or 3 h rated duration
- Operating time selectable with plug (duration link)
- Compatible with all dimmable and non-dimmable constant current LED Driver (see 5.3, LED Driver compatibility)
- 3-pole technology: 2-pole LED module changeover and delayed power switching for the LED Driver
- Automatic shutdown of output if LED load is out of range
- Constant power output
- Maximum light output for all LED modules
- Electronic charge system
- Deep discharge protection
- Short-circuit-proof battery connection
- Polarity reversal protection for battery

Batteries

- High-temperature cells
- NiCd or NiMH batteries
- D, Cs or LA cells
- 4-year design life
- 1-year guarantee
- For battery compatibility refer to chapter „Battery selection“



Standards, page 4

Wiring diagrams and installation examples, page 5

EM converterLED BASIC 50 V

BASIC series

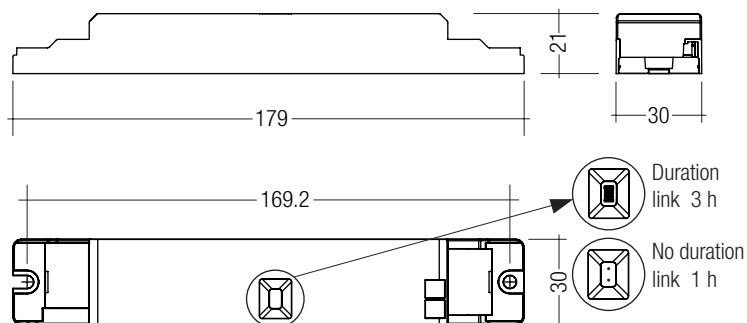

Note: LED Driver supplied with duration link in 3 hours position. Remove duration link for 1 hour duration. Duration link must be set before battery and mains connection. The EM converterLED BASIC 134 NiCd is supplied without a duration link. The duration is set to 3 hours and cannot be changed.

Technical data

Rated supply voltage	220 – 240 V
Mains frequency	50 / 60 Hz
Typ. λ (at 230 V, 50 Hz)	0.6
LED module forward voltage range	10 – 52 V
Output current	see page 5
Time to light	< 0,25 s from detection of emergency event
Overvoltage protection	320 V (for 1 h)
Maximum output voltage	60 V
Battery charging time	20 h ^①
Ambient temperature range t_a	-5 ... + 55 °C
Max. casing temperature t_c	70 °C
Mains voltage changeover threshold	according to EN 60598-2-22
Type of protection	IP20

Ordering data

Type ^②	Article number	Rated duration	Number of cells	Packaging, carton	Packaging, pallet	Weight per pc.
EM converterLED BASIC 103 50V	89800178	1/3 h	3	10 pc(s).	1,600 pc(s).	0.077 kg
EM converterLED BASIC 104 50V	89800179	1/3 h	4	10 pc(s).	1,600 pc(s).	0.078 kg
EM converterLED BASIC 134 NiCd 50V	89800180	3 h	4	10 pc(s).	1,600 pc(s).	0.078 kg

Specific technical data

Type ^②	Rated duration	Typ. output power	Mains current in charging operation	Rated power in charging operation
EM converterLED BASIC 103 50V	1 h	2.75 W	25 mA	3.0 W
	3 h	2.75 W	30 mA	3.7 W
EM converterLED BASIC 104 50V	1 h	3.50 W	27 mA	3.0 W
	3 h	3.50 W	35 mA	4.0 W
EM converterLED BASIC 134 NiCd 50V	3 h	1.35 W	27 mA	3.0 W

^① 16 h battery charging time for 2 h emergency lighting function according to AS 2293.

^② EM = Emergency

RoHS

ACCES-
SORIES

Test switch EM3

Product description

- For connection to the emergency lighting unit
- For checking the device function
- Plug connection



Ordering data

Type	Article number	Packaging, bag	Packaging, carton	Weight per pc.
Test switch EM 3	89899956	25 pc(s).	200 pc(s).	0.013 kg

ACCES-
SORIES

Status indication green LED

Product description

- A green LED indicates that charging current is flowing into the battery
- Plug connection



Ordering data

Type	Article number	Packaging, bag	Packaging, carton	Weight per pc.
LED EM green, 1.0 m CON	89800269	25 pc(s).	200 pc(s).	0.015 kg
LED EM green, HO 1.0 m CON	89800271	25 pc(s).	200 pc(s).	0.015 kg
LED EM green, 0.6 m CON	89800472	25 pc(s).	200 pc(s).	0.009 kg
LED EM green, HO 0.6 m CON	89800473	25 pc(s).	200 pc(s).	0.009 kg
LED EM green, 0.3 m CON	89800270	25 pc(s).	200 pc(s).	0.005 kg
LED EM green, HO 0.3 m CON	89800272	25 pc(s).	200 pc(s).	0.005 kg

1. Standards

- according to EN 50172
- according to EN 60598-2-22
- EN 61347-1:2008+A2:2013
- EN 61347-2-13
- EN 61347-2-7
- EN 55015
- EN 61000-3-2
- EN 61000-3-3
- EN 61547
- EN 60068-2-64
- EN 60068-2-29
- EN 60068-2-30
- EN 62384

Meaning of marking

Double or reinforced insulation for built-in electronic LED Drivers

1.1 Glow-wire test

according to EN 61347-1 with increased temperature of 850 °C passed.

1.2 Isolation and electric strength testing of luminaires

Electronic LED-Drivers can be damaged by high voltage. This has to be considered during the routine testing of the luminaires in production.

According to IEC 60598-1 Annex Q (informative only!) or ENEC 303-Annex A, each luminaire should be submitted to an isolation test with 500 Vdc for 1 second. This test voltage should be connected between the interconnected phase and neutral terminals and the earth terminal. The isolation resistance must be at least 2 MΩ.

As an alternative, IEC 60598-1 Annex Q describes a test of the electrical strength with 1,500 VAC (or 1,414 x 1,500 Vdc). To avoid damage to the electronic devices this test **must not be conducted**.

2. Thermal details and life-time

2.1 Life-time

Average life-time 50,000 hours under rated conditions with a failure rate of less than 10 %. Average failure rate of 0.2% per 1000 operating hours.

3. Installation / Wiring

3.1 Wiring diagram

One or more LED modules with a total forward voltage of 10 to 52 V can be connected to the EM converterLED 50V module. These LED module(s), marked with "Emergency" are operated in emergency mode from the associated battery. In normal mains mode all LED modules are operated by the mains LED Driver.

Use of the test switch:

For checking the device function press the test switch for a minimum of 3 seconds.

EM converterLED BASIC with one LED module for non-maintained emergency operation

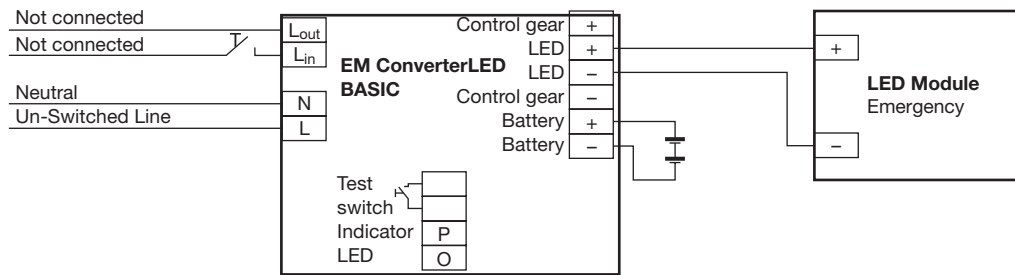

EM converterLED BASIC with a standard LED Driver and one LED module for mains and emergency operation

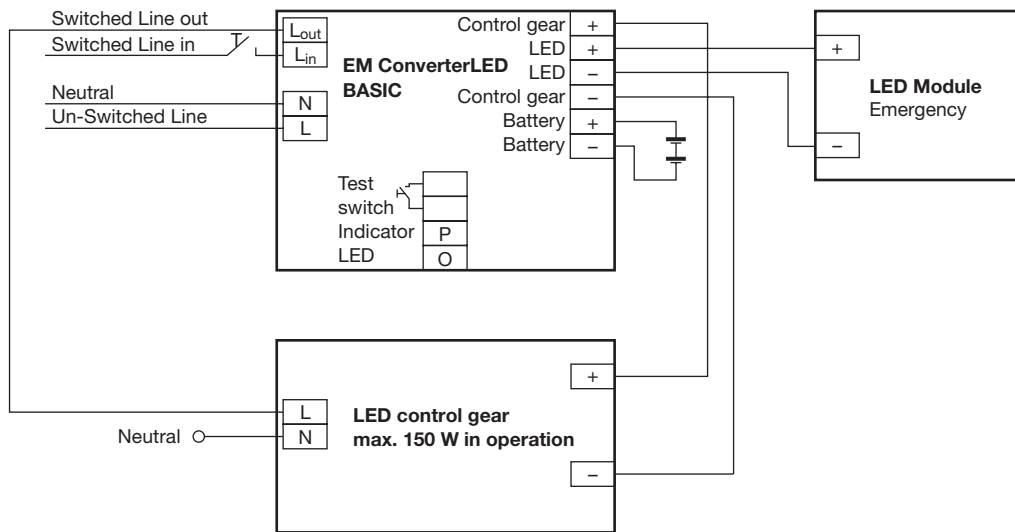

EM converterLED BASIC with a standard LED Driver and series operation of LED modules

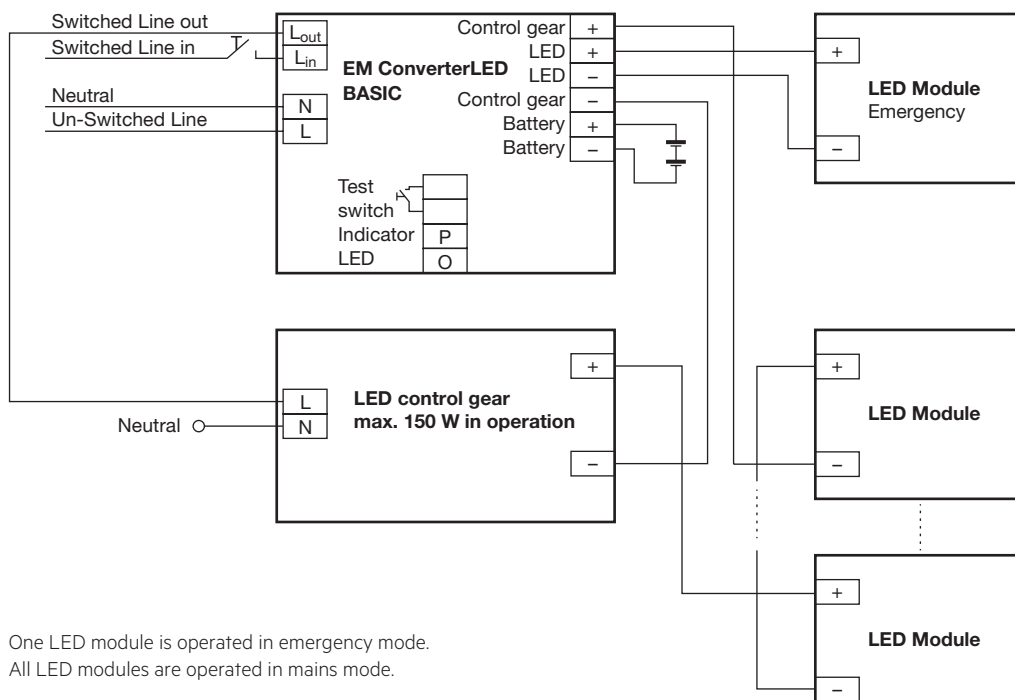

One LED module is operated in emergency mode.
All LED modules are operated in mains mode.

EM converterLED BASIC with a standard LED Driver and series operation of LED modules

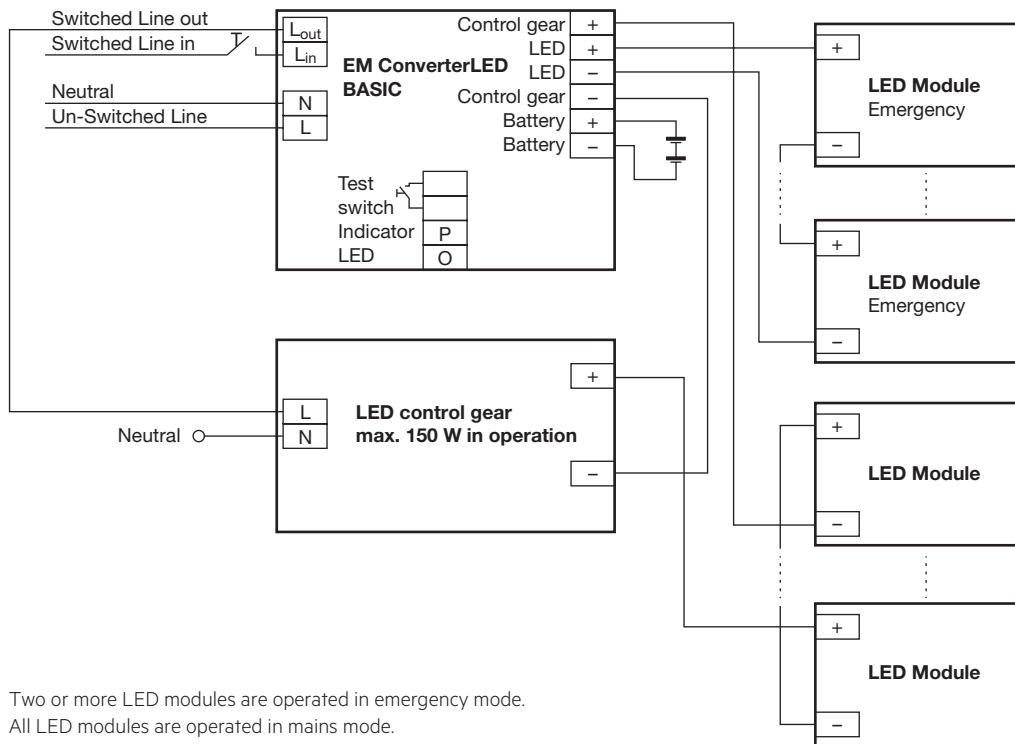

Two or more LED modules are operated in emergency mode.
All LED modules are operated in mains mode.

EM converterLED BASIC with a standard LED Driver and parallel operation of LED modules

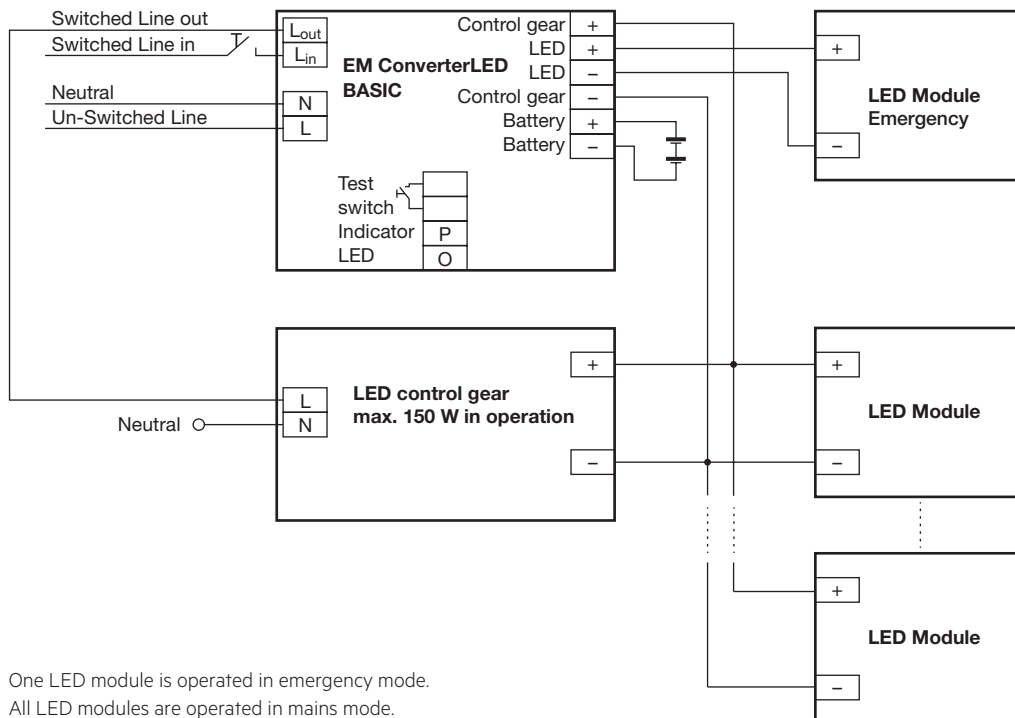

One LED module is operated in emergency mode.
All LED modules are operated in mains mode.

EM converterLED BASIC with a standard LED Driver and parallel operation of LED modules

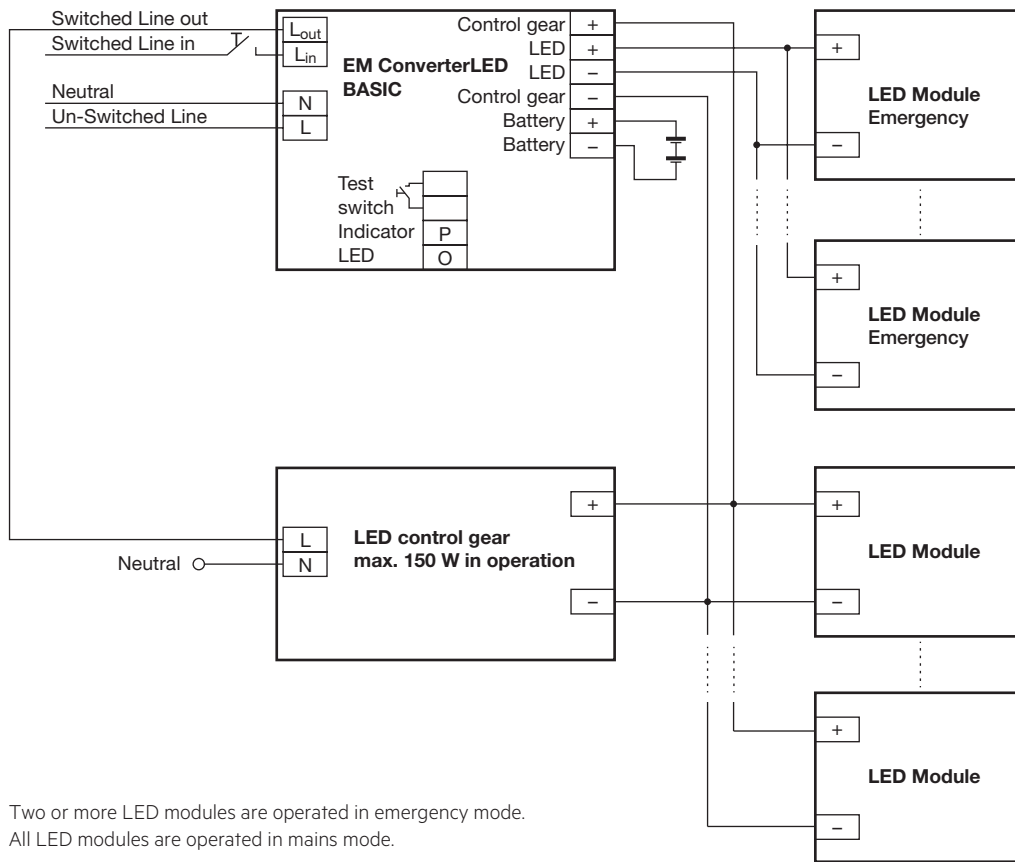

Two or more LED modules are operated in emergency mode.
All LED modules are operated in mains mode.

3.2 Wiring type and cross section

Solid wire with a cross section of 0.5 – 1.5 mm². Strip 8 – 9 mm of insulation from the cables to ensure perfect operation of terminals.

Wiring: LED module/LED Driver/supply

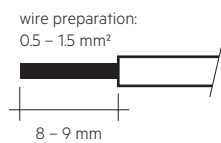

3.3 Loose wiring

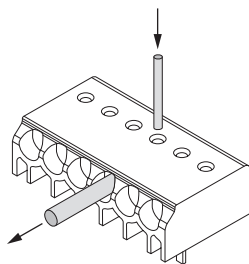

Loosen wire through twisting and pulling or using a Ø 1 mm release tool

3.4 Wiring guidelines

- The LED terminals, battery, indicator LED and test switch terminals are classified as SELV (output voltage < 60 V DC). Keep the wiring of the input terminals separated from the wiring of the SELV equivalent terminals or consider special wiring (double insulation, 6 mm creepage and clearance) when these connections should be kept SELV.
- The output to the LED is DC but has high frequency content, which should be considered for good EMC compliance.
- LED leads should be separated from the mains connections and wiring for good EMC performance.
- Maximum lead length on the LED terminals is 3 m. For a good EMC performance keep the LED wiring as short as possible.
- Maximum lead length for the test switch and Indicator LED connection is 1 m. The test switch and Indicator LED wiring should be separated from the LED leads to prevent noise coupling.
- Battery leads are specified with 0.5 mm cross section and a length of 1.3 m
- To avoid the damage of the control gear, the wiring must be protected against short circuits to earth (sharp edged metal parts, metal cable clips, louver, etc.).

To ensure that a luminaire containing LED emergency units complies with EN 55015 for radio frequency conducted interference in both normal and emergency mode it is essential to follow good practice in the wiring layout.

Within the luminaire the switched and unswitched 50 Hz supply wiring must be routed as short as possible and be kept as far away as possible from the LED leads. Through wiring may affect the emc performance of the luminaire.

The length of LED leads must not be exceeded. Note that the length of the EM converterLED leads is added to the length of the leads from the LED Driver to the EM converterLED module when considering max. permitted lead length of the LED Driver.

3.5 Maximum lead length

LED	3 m ^①
Status indication LED	1 m
Batteries	1.3 m

^① Note: The length of LED leads to the LED module must not be exceeded. Note that the length of the EM converterLED leads is added to the length of the leads from the LED Driver to the EM converterLED module when considering max. permitted lead length of the LED Driver. Leads should always be kept as short as possible.

3.6 Use of different phases

The use of different phases for switched line and unswitched line is allowed. When using different phases, the unswitched line must fail if the switched line fails. This is required to assure correct switching into emergency mode. It can be realised with a relay.

4. Mechanical values

4.1 Housing properties

Casing manufactured from polycarbonate.

4.2 Mechanical data accessories

LED status indicator

- Green
- Mounting hole 6.5 mm dia
- Lead length 0.3 m / 1.0 m
- Insulation rating: 90 °C
- Plug connection

Test switch

- Mounting hole 7.0 mm dia
- Lead length 0.55 m
- Plug connection

Battery leads

- Quantity: 1 red and 1 black
- Length: 1.3 m
- Wire type: 0.5 mm² solid conductor
- Insulation rating: 90 °C

Battery end termination

Push on 4.8 mm receptacle to suit battery spade fitted with insulating cover

Module end termination

8.0 mm stripped insulation

Two-piece batteries are supplied with a 200 mm lead with 4.8 mm receptacle at each end and insulating covers to connect the separate sticks together.

5. Electrical values

5.1 Maximum loading of automatic circuit breakers

Automatic circuit breaker type	B10	B13	B16	B20	C10	C13	C16	C20	Inrush current	
Installation \varnothing	1.5 mm ²	1.5 mm ²	1.5 mm ²	2.5 mm ²	1.5 mm ²	1.5 mm ²	1.5 mm ²	2.5 mm ²	I_{max}	time
EM converterLED 103 BASIC 50V	90	130	130	130	180	260	260	260	10 A	120 μ s
EM converterLED 104 BASIC 50V	90	130	130	130	180	260	260	260	10 A	120 μ s

5.2 Typ. LED current/voltage characteristics

The LED current in emergency mode is automatically adjusted by the EM converterLED module based on the total forward voltage of the LED modules connected and the associated battery.

EM converterLED BASIC 103 50V

Article number: 89800178

3.6 V battery voltage

750 – 960 mA battery discharge current (tolerance)

EM converterLED BASIC 104 50V

Article number: 89800179

4.8 V battery voltage

750 – 960 mA battery discharge current (tolerance)

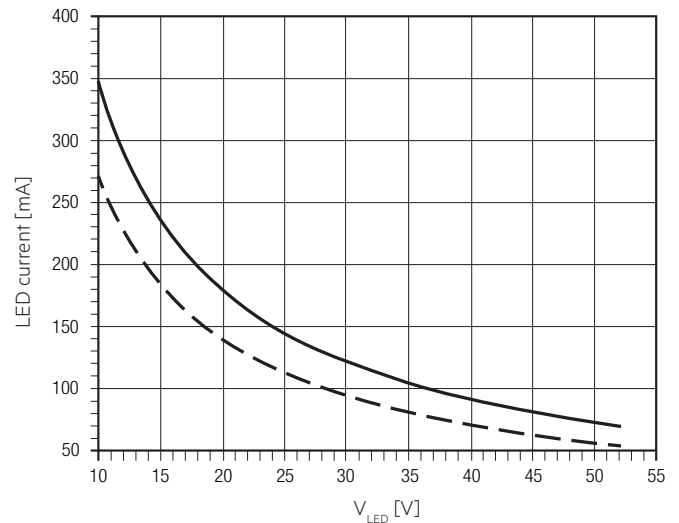
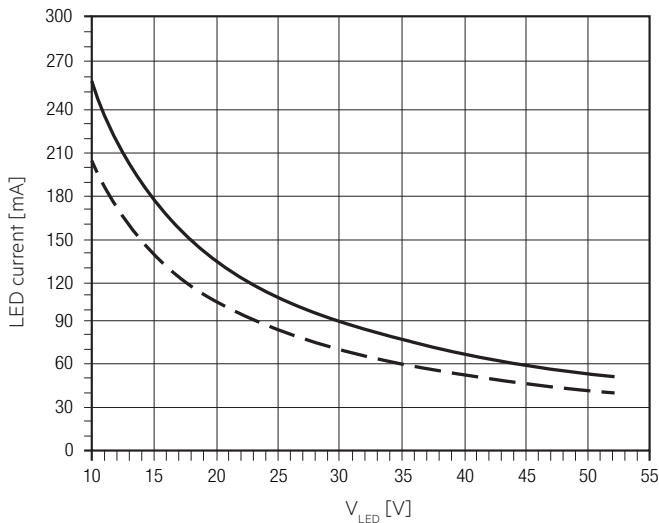

LED peak current at start in emergency mode – 3 cells

Voltage	Inrush current	Duration
16.0 V	478 mA	11.0 ms
18.6 V	439 mA	9.6 ms
21.2 V	407 mA	8.2 ms
23.7 V	377 mA	7.8 ms
26.3 V	356 mA	7.0 ms
31.4 V	315 mA	6.3 ms
33.9 V	302 mA	5.6 ms
36.4 V	290 mA	5.2 ms
38.9 V	275 mA	4.7 ms
41.5 V	262 mA	4.3 ms
44.0 V	252 mA	3.9 ms
46.6 V	244 mA	3.6 ms
49.0 V	234 mA	3.5 ms
51.6 V	228 mA	3.3 ms

LED peak current at start in emergency mode – 4 cells

Voltage	Inrush current	Duration
16.2 V	466 mA	17.0 ms
18.8 V	435 mA	13.4 ms
21.3 V	407 mA	11.5 ms
23.9 V	385 mA	10.8 ms
26.5 V	365 mA	9.5 ms
31.6 V	333 mA	7.8 ms
34.2 V	321 mA	6.5 ms
36.7 V	308 mA	6.0 ms
39.3 V	295 mA	5.5 ms
41.8 V	286 mA	5.3 ms
44.3 V	277 mA	5.1 ms
46.9 V	270 mA	4.9 ms
49.4 V	262 mA	4.4 ms
51.9 V	255 mA	4.2 ms

Note: LED peak current measured at the max. battery discharge current and at a max. battery voltage of 4.5 V (3 cells) or 6 V (4 cells).

EM converterLED BASIC 134 NICD 50V
 Article number: 89800180
 4.8 V battery voltage
 290 – 370 mA battery discharge current (tolerance)

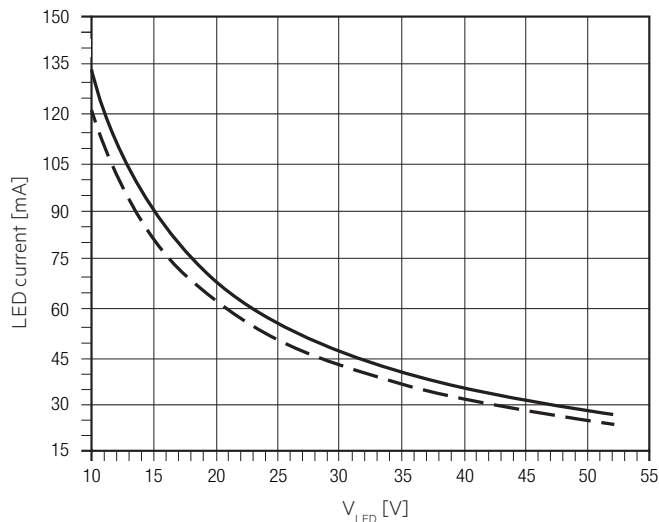

LED peak current at start in emergency mode – 4 cells

Voltage	Inrush current	Duration
15.8 V	406 mA	14.5 ms
18.3 V	378 mA	12.5 ms
20.8 V	359 mA	10.8 ms
23.4 V	346 mA	9.7 ms
25.9 V	330 mA	9.0 ms
28.4 V	316 mA	8.1 ms
30.9 V	308 mA	7.8 ms
33.5 V	295 mA	7.0 ms
36.0 V	287 mA	6.3 ms
38.5 V	275 mA	5.9 ms
41.0 V	267 mA	5.7 ms
43.5 V	258 mA	5.1 ms
46.0 V	252 mA	4.2 ms
48.5 V	244 mA	4.0 ms

- LED current at nominal battery voltage and min. battery discharge current
- LED current at nominal battery voltage and max. battery discharge current

5.3 LED Driver compatibility

The EM converterLED emergency unit use 3 pole technology and is compatible with most LED Drivers on the market, however it is important to check that the rating of the LED Driver does not exceed the values specified below:

- The max. allowed output current rating of the associated LED Driver is 2.4 A peak (current rating of switching relays of EM converterLED)
- The max. allowed inrush current rating of the associated LED Driver is 60 A peak for 1 ms or 84 A for 255 μs (inrush current rating of switching relay of EM converterLED)
- The max. allowed output voltage of the associated LED Driver applied to the EM converterLED output is 450V (voltage withstand between adjacent contact of the single switching relay of the EM converterLED)
- The max. allowed LED load of the associated LED Driver is 150 W in operation. The load must be an LED module.

6. Functions

6.1 Duration link selection

Duration	Usage duration link
3 h	With link
1 h	Without link

Emergency lighting LED Driver supplied with duration link in 3 hours position.

The position of the link will only be read on first power up. If it is changed afterwards both the battery and mains supply must be disconnected for 10 seconds to enable the EM converterLED to read the new link position on reconnection of the battery and mains. It will lead to a false battery failure indication if the link is changed after installation without this reset.

7. Battery data

7.1 Battery selection

EM converterLED BASIC, 1/ 3 h

		Type	EM converterLED BASIC 103 50V	EM converterLED BASIC 104 50V	EM converterLED BASIC 134 50V
		Article no.	89800178	89800179	89800180
		Cells	3 cells	4 cells	4 cells
		Duration	1 h	3 h	3 h
Technology and capacity	Design	Number of cells	Type	Article no.	Assignable batteries
NiCd 1.6 Ah Cs cells	stick	1 x 3	Accu-NiCd C 3A	89899743	•
	stick	1 x 4	Accu-NiCd C 4A	89899692	•
	stick + stick	2 + 2	Accu-NiCd C 4C	89899694	•
	side by side	4 x 1	Accu-NiCd C 4B	89899693	•
NiCd 4 Ah D cells	stick	1 x 3	Accu-NiCd 3A	89895960	•
	stick	1 x 4	Accu-NiCd 4A 55	89800089	•
	side by side	3 x 1	Accu-NiCd 3B 55	89800384	•
	side by side	4 x 1	Accu-NiCd 4B 55	89800385	•
NiMH 2.2 Ah Cs cells	stick	1 x 3	Accu-NiMH 3A	28002088	•
	stick	1 x 4	Accu-NiMH 4A	28002089	•
NiMH 4 Ah LA cells	stick	1 x 3	Accu-NiMH 4Ah 3A CON	89800441	•
	stick	1 x 4	Accu-NiMH 4Ah 4A CON	89800442	•
	stick + stick	2 + 2	Accu-NiMH 4Ah 4C CON	89800438	•

7.2 Battery charge / discharge data

EM converterLED BASIC, 1/ 3 h

Type	EM converterLED BASIC 103 50V		EM converterLED BASIC 104 50V		EM converterLED BASIC 134 50V
Article no.	89800178		89800179		89800180
Cells	3 cells		4 cells		4 cells
Duration	1 h	3 h	1 h	3 h	3 h
Charging current	105 mA	210 mA	105 mA	210 mA	105 mA
Discharge current	750 – 960 mA	750 – 960 mA	750 – 960 mA	750 – 960 mA	290 – 370 mA

7.3 Accu-NiCd**1.6 Ah**

Battery voltage/cell	1.2 V
Cell type	Cs
Case temperature range to ensure 4 years design life	+5 °C to +50 °C
Max. short term temperature (reduced life-time)	70 °C
Max. number discharge cycles	4 cycles per year plus 4 cycles during comissioning
Max. storage time	6 months

4.2 / 4.5 Ah

Battery voltage/cell	1.2 V
Cell type	D
Case temperature range to ensure 4 years design life	+5 °C to +55 °C
Max. short term temperature (reduced life-time)	70 °C
Max. number discharge cycles	4 cycles per year plus 4 cycles during comissioning
Max. storage time	6 months

7.4 Accu-NiMH**2.2 Ah**

Battery voltage/cell	1.2 V
Cell type	Cs
Case temperature range to ensure 4 years design life	+5 °C to +50 °C
Max. short term temperature (reduced life-time)	70 °C
Max. number discharge cycles	4 cycles per year plus 30 cycles during comissioning
Max. storage time	6 months

4.0 Ah

Battery voltage/cell	1.2 V
Cell type	LA
Case temperature range to ensure 4 years design life	+5 °C to +40 °C
Max. short term temperature (reduced life-time)	70 °C
Max. number discharge cycles	4 cycles per year plus 30 cycles during comissioning
Max. storage time	6 months

7.5 Wiring batteries

Connection method: 4.8 x 0.5 mm spade tag welded to end of cell.

For stick packs this connection is accessible after the battery caps have been fitted.

To inhibit inverter operation disconnect the batteries by removing the connector from the battery spade tag.

For further information refer to corresponding battery datasheet.

7.6 Storage, installation and commissioning

Relevant information about storage conditions, installation and commissioning are provided in the battery datasheets.

8. Miscellaneous**8.1 Additional information**

Additional technical information at www.tridonic.com → Technical Data

Guarantee conditions at www.tridonic.com → Services

Life-time declarations are informative and represent no warranty claim.
No warranty if device was opened.